

## Design Assistance Datasheet

For fastest service, also email your 3D part files to: [sales@reflexautomation.com](mailto:sales@reflexautomation.com)

### A Customer Information

Company: \_\_\_\_\_  
 Contact: \_\_\_\_\_  
 Address: \_\_\_\_\_  
 Address: \_\_\_\_\_  
 City: \_\_\_\_\_ State: \_\_\_\_\_ Pin: \_\_\_\_\_  
 Tel: \_\_\_\_\_  
 Fax: \_\_\_\_\_  
 Email: \_\_\_\_\_

### B Part Information

Name of part: \_\_\_\_\_  
 Sample parts sent       2D Mold drawing sent  
 3D CAD drawing sent      Filename: \_\_\_\_\_  
 Material: \_\_\_\_\_  
 Part Temperature: \_\_\_\_\_  
 Total shot weight: \_\_\_\_\_  
 Individual part weight: \_\_\_\_\_  
 Number of cavities: \_\_\_\_\_  
 Part surface:  Smooth    Textured    Other:  
 Other considerations:  Cosmetic    Painted afterwards  
 Other: \_\_\_\_\_

### C Mold Information

Cycle time: \_\_\_\_\_  
 Type of mold:  Hot runner    Subgated    Cold runner  
 Standard 2-plate mold    3-plate mold  
 Vertical corepull    Other:  
 Number of sprues: \_\_\_\_\_  
 Sprue diameter: \_\_\_\_\_  
 Sprue length: \_\_\_\_\_  
 Ejection:  Moving half    Fixed half  
 Do parts come straight off ejector pins:  Y    N  
 Any force required to remove parts:  Y    N  
 Any twisting, bending, lifting required to remove parts:  Y    N  
 Explain: \_\_\_\_\_

### D Robot Information

Robot manufacturer: \_\_\_\_\_  
 Robot type:  6-axis    3-axis servo    3-axis AC or pneumatic  
 sprue picker  
 Robot entry:  Top    Side      Robot mounting:  Platen    Floor  
 Robot wrist flip:  Y    N      Robot wrist rotation:  Y    N  
 Robot payload capacity (lbs.): \_\_\_\_\_  
 Signaling:  PNP    NPN  
 Is vacuum detection circuit present:  Y    N  
 Number of compressed air circuits available: \_\_\_\_\_  
 Number of vacuum circuits available: \_\_\_\_\_  
 Does robot have an existing Quick-Changer:  Y    N  
 If yes, describe type: \_\_\_\_\_  
 Additional comments: \_\_\_\_\_

### E Degating Information

Required:  Y    N      on EOAT, separate degate station  
 Total number of gates & sprues to cut: \_\_\_\_\_  
 Gate diameter (or if fan gate; WxH): \_\_\_\_\_  
 Maximum allowable vestige: \_\_\_\_\_  
 \_\_\_\_\_  
 Brand preference: \_\_\_\_\_  
 Additional comments: \_\_\_\_\_

### F Part Handling

Part placement:  Conveyor    Pallet    Box/case  
 Is stacking required:  Y    N      Sketch stacking requirement  
 Is paper/cardboard separation layer required:  Y    N  
 Insert Loading:  Y    N  
 Insert loading on:  Fixed mold half    Moving mold half  
 Weight of inserts: \_\_\_\_\_      Sample inserts sent:  Y    N  
 How are inserts presented to robot: \_\_\_\_\_

### G Other:

For fastest service, also email your 3D part files to: sales@reflexautomation.com

## Design Assistance Datasheet

### Machine Dimensions

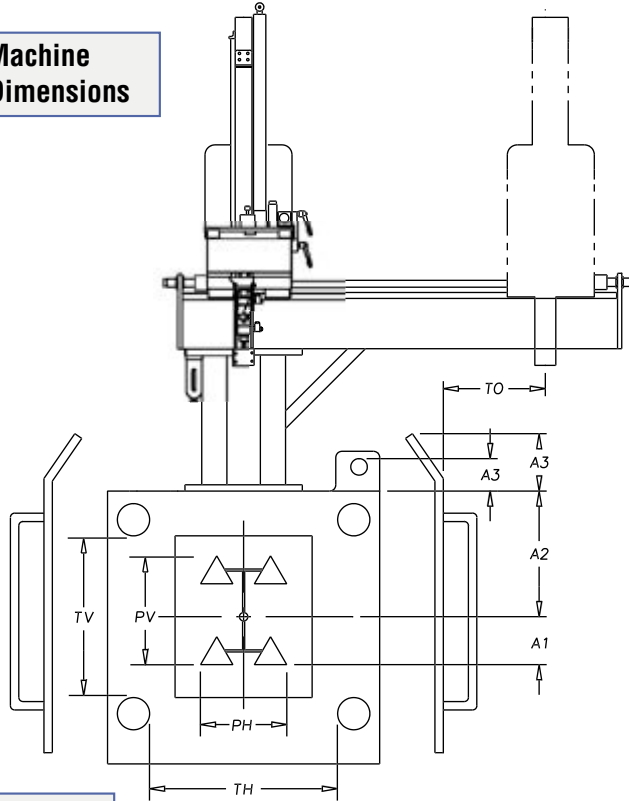

### H Dimensions:

Machine	Fill-In:
Between Tie Bars - Horizontal	<b>TH</b>
Between Tie Bars - Vertical	<b>TV</b>
Overall Part Length - Horizontal	<b>PH</b>
Overall Part Length - Vertical	<b>PV</b>
Nozzle Centerline to Bottom of Parts	<b>A1</b>
Nozzle Centerline to Top of Platen	<b>A2</b>
Top of Platen to Highest Obstruction	<b>A3</b>
Overall Traversing Clearance	<b>TO</b>
Robot	
Vertical Stroke	<b>VS</b>
Robot Beam Clearance when fully up	<b>BC</b>
Robot Arm - Overall Width	<b>RA</b>
Horizontal Adjustment	<b>HA</b>
Horizontal Stroke	<b>HS</b>
Tooling Plate Length	<b>TP</b>
Mold	
Mold Opening	<b>MO</b>
Ejector Stroke	<b>ES</b>
Fixed Mold Half Height	<b>FM</b>
Tooling Plate / Mounting Plate	
Sketch All Holes	

### Robot Dimensions

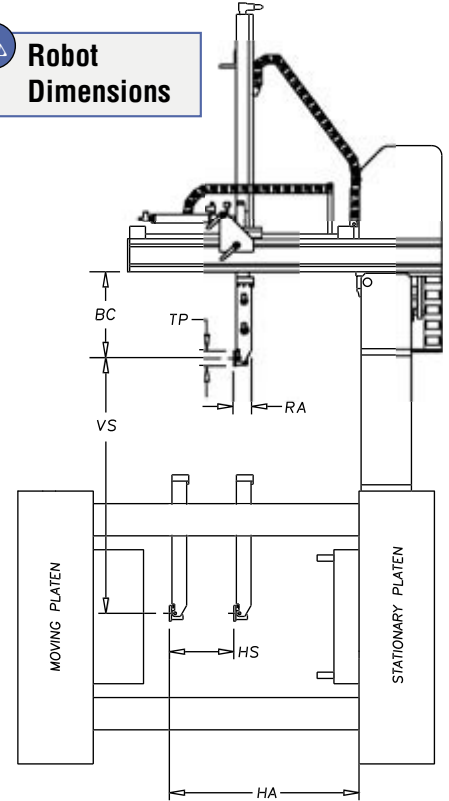

### Mold Dimensions

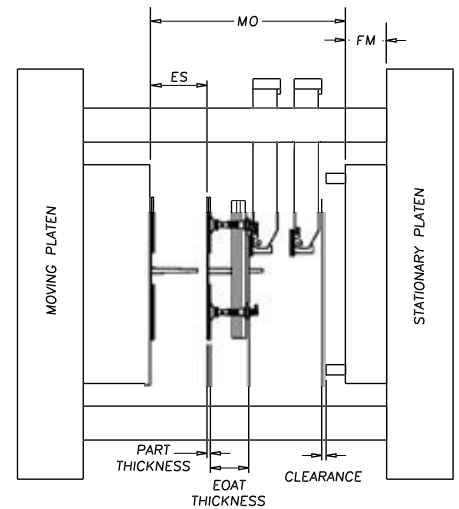

### Tooling Plate Dimensions

Sketch all holes and obstructions

